



## **VEGA 100 - VEGA 200 - VEGA 200SL MULTI FUEL STOVES**

**CE** APPROVED - CONFORMING TO EN13240:2001 and  
EN13240 A2:2004

### **INSTALLATION AND OPERATING INSTRUCTIONS**

**STOVES MUST BE FITTED BY APPROVED, QUALIFIED AND  
COMPETENT INSTALLERS**

### **PLEASE LEAVE THIS BOOKLET WITH THE HOUSEHOLDER**

**Penman Stoves operate at very high temperatures. All persons  
including children and the infirm should be warned of this and not  
allowed to touch any surfaces whilst in use. The operator must use  
the glove provided.**

[www.penmancollection.com](http://www.penmancollection.com)

## **CONTENTS**

STOVE CONTROLS, OUTPUT & EFFICIENCY	PAGE 03
COMPONENT PARTS	PAGE 04
INSTALLATION	PAGE 05
OPERATION	PAGE 10
GENERAL MAINTENANCE	PAGE 16
SAFETY NOTES & TROUBLESHOOTING	PAGE 18
STOVE ACCESSORIES	PAGE 21

## YOUR STOVE, OPERATING CONTROLS, OUTPUT AND EFFICIENCY

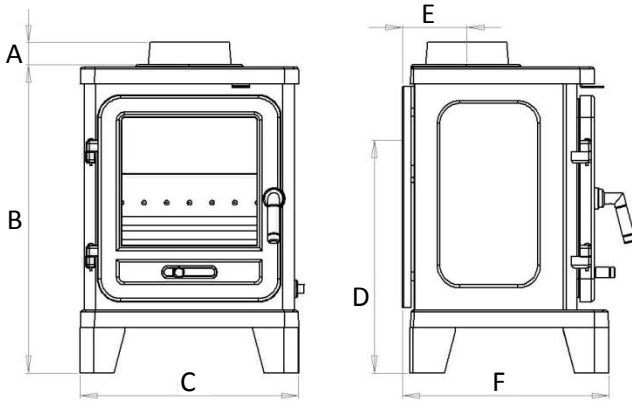

	A	B	C	D	E	F
VEGA EDGE 100	40mm	543mm	385mm	420mm	114mm	364mm
VEGA EDGE 200	48mm	594mm	501mm	454mm	144mm	393mm
VEGA EDGE 200SL	48mm	594mm	501mm	454mm	114mm	333mm

	VEGA EDGE 100		VEGA EDGE 200		VEGA EDGE 200SL	
	WOOD	ANTHRACITE	WOOD	ANTHRACITE	WOOD	ANTHRACITE
EFFICIENCY	76.2%	74.2%	81.1%	70.9%	84%	71.5%
FLUE GAS TEMPERATURE	270 °C	290°C	280 °C	333°C	244 °C	280°C
EMISSION OF CO @ 13% O2	0.31%	0.15%	0.32%	0.12%	0.11%	0.24%
RATED OUTPUT	4.9kW		8kW		5kW	
WEIGHT	83KG		104KG		91KG	

Outputs stated are under ideal test conditions carried out at SGS Environmental Services in the Netherlands. Variations may occur due to installation, atmospheric conditions and fuel quality.

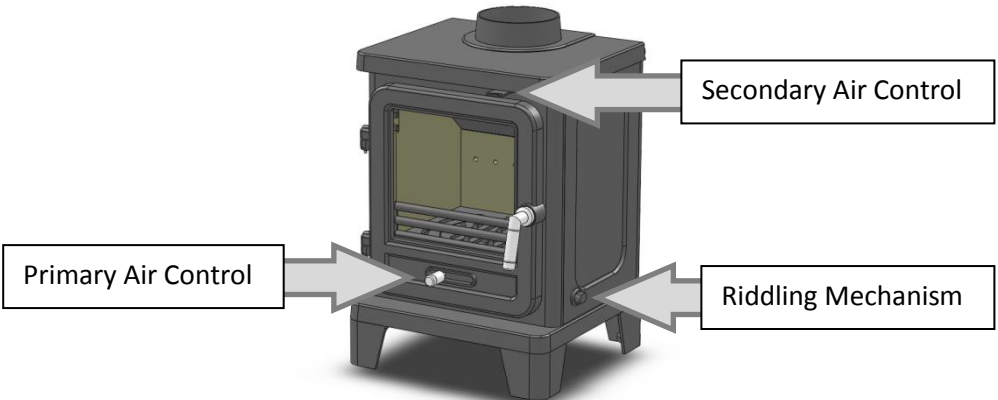

## COMPONENT PARTS

Many spare parts are stocked – please refer to your retailer or supplier if you require any replacement parts.

Please only use components made specifically for your stove.

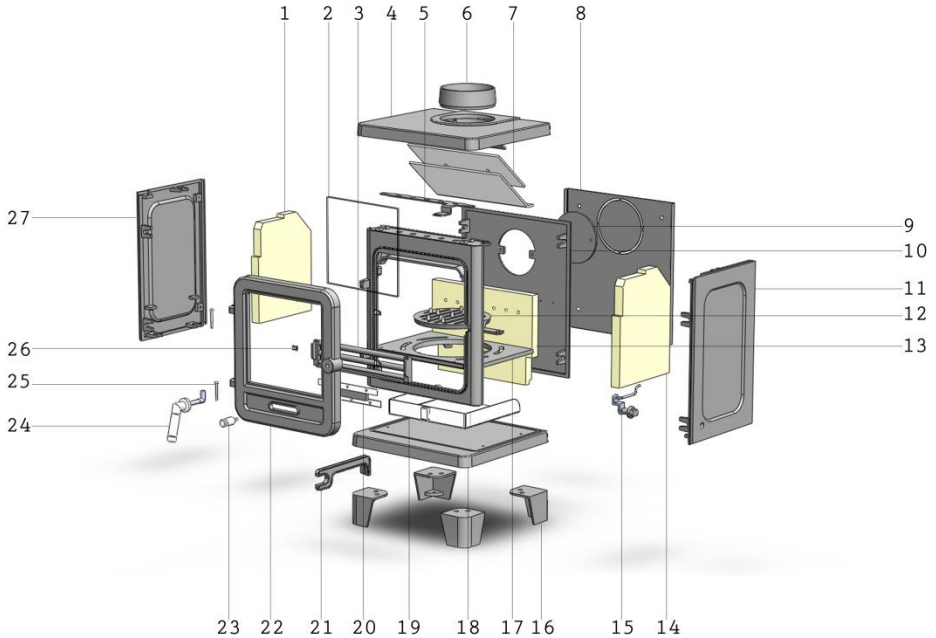

ITEM	DESCRIPTION	ITEM	DESCRIPTION
1	Left fire brick	15	Riddling mechanism
2	Glass panel	16	4 x stove legs
3	Front bar	17	Outer grate
4	Stove top panel	18	Stove bottom panel
5	Secondary air control plate	19	Ash Pan
6	Flue collar	20	Primary air slide plate
7	Baffle plate	21	Stove tool
8	Heat shield	22	Stove door
9	Flue blanking plate	23	Primary air control knob
10	Stove rear panel	24	Handle assembly
11	Stove right side panel	25	2 x door hinge pins
12	Inner grate	26	4 x glass retaining clips
13	Rear fire brick	27	Stove left side panel
14	Right fire brick	28	

## **INSTALLATION, OPERATION AND MAINTENANCE**

**IMPORTANT: THIS APPLIANCE MUST BE INSTALLED BY A COMPETENT PERSON AND THE INSTALLATION MUST COMPLY WITH BS8303 – CODE OF PRACTICE FOR INSTALLATION OF DOMESTIC HEATING AND COOKING APPLIANCES BURNING SOLID MINERAL FUEL, NATIONAL BUILDING REGULATIONS, LOCAL BY-LAWS AND STANDARDS AND THE REQUIREMENTS OF THE HEALTH AND SAFETY AT WORK ACT - IN PARTICULAR:**

**HANDLING** – ADEQUATE FACILITIES MUST BE AVAILABLE FOR LOADING, UNLOADING AND SITE HANDLING.

**FIRE CEMENT** – SOME TYPES ARE CAUSTIC AND SHOULD NOT BE ALLOWED TO COME INTO CONTACT WITH THE SKIN. IN CASE OF CONTACT WASH IMMEDIATELY WITH PLENTY OF WATER.

**ASBESTOS** – THESE STOVES CONTAIN NO ASBESTOS. IF THERE IS A POSSIBILITY OF DISTURBING ANY ASBESTOS IN THE COURSE OF INSTALLATION THEN PLEASE SEEK THE GUIDANCE OF A SPECIALIST AND USE APPROPRIATE PROTECTIVE EQUIPMENT.

**METAL PARTS** – WHEN INSTALLING OR SERVICING THIS STOVE CARE SHOULD BE TAKEN TO AVOID THE POSSIBILITY OF PERSONAL INJURY

**UNLESS THE INSTALLER IS QUALIFIED TO APPROVE INSTALLATION THEN APPROVAL MUST BE SOUGHT FROM YOUR LOCAL BUILDING CONTROL DEPARTMENT. THE SUPPLIERS ACCEPT NO RESPONSIBILITY IF THIS ADVICE IS NOT FOLLOWED. THIS APPLIANCE HAS BEEN EXTENSIVELY TESTED FOR SAFETY AND EFFICIENCY, DO NOT ATTEMPT TO MODIFY IT. ALWAYS USE GENUINE REPLACEMENT PARTS AS RECOMMENDED BY YOUR SUPPLIER. FAILURE TO ADHERE TO THIS ADVICE WILL INVALIDATE YOUR GUARANTEE.**

**TRY TO AVOID FITTING AN EXTRACTOR FAN IN THE SAME ROOM AS THIS STOVE. IF THIS IS UNAVOIDABLE THEN SEEK SPECIALIST ADVICE TO ENSURE THAT THE INSTALLATION IS TESTED FOR SAFETY. A SUITABLE TEST COMPRISES CHECKING FOR SPILLAGE IF THE ROOM WHERE THE APPLIANCE IS FITTED IS SUBJECTED TO THE GREATEST POSSIBLE DEPRESSURISATION. THIS MEANS FIRING THE APPLIANCE WITH ALL THE EXTRACT FANS IN THE BUILDING OPERATING AT THEIR MAXIMUM AND WITH ALL DOORS, ADJUSTABLE VENTILATORS AND WINDOWS CLOSED. IF SPILLAGE OCCURS THEN ADDITIONAL PERMANENT VENTILATION DIRECT FROM OUTSIDE WILL BE REQUIRED. ONCE THE ADDITIONAL VENTILATION IS FITTED, RETEST AS NOTED ABOVE,**

**IT IS ESSENTIAL AND REQUIRED BY BUILDING REGULATIONS THAT A CARBON MONOXIDE (CO) ALARM IS INSTALLED IN THE SAME ROOM AS THIS STOVE.**

**THIS STOVE MUST HAVE ITS OWN CHIMNEY AND MUST NOT SHARE A CHIMNEY WITH ANOTHER APPLIANCE.**

**THIS STOVE IS FOR INTERMITTENT USE ONLY AND SHOULD BE SHUT DOWN OVERNIGHT.**

**VENTILATION MAY BE REQUIRED INTO YOUR ROOM, PLEASE SEE PAGE 9.**

## INSTALLATION

Once the installation is complete, the installer must advise the householder on the correct use of the stove and warn them to use only the recommended fuels listed in this document. The installer must also advise the householder on the actions to be taken should smoke or fumes be emitted from the stove.

Your Penman stove must not share a chimney with any other appliance

Where the chimney is believed to have previously served an open fire installation it is possible that the higher flue gas temperature from a closed appliance may loosen deposits that were previously firmly adhered, with the consequent risk of flue blockage. It is therefore recommended that the chimney be swept a second time within a month of regular use after installation.

Check the chimney is in good condition, dry, free from cracks, leaks and obstructions. The diameter of the flue should not be less than 150mm and not more than 230mm. If any of these requirements are not met, the chimney should be lined by a suitable method.

When installing a **Vega Edge 100** a 125mm flue liner may be used in accordance with the Building Regulations. When installing a **Vega Edge 200 or Vega Edge 200SL** a 150mm flue liner may be used in accordance with the Building Regulations. The chimney and connecting flue pipe should not narrow to less than the size of the outlet socket (collar) of the stove at any point.

The chimney height and the position of the chimney terminal must conform to Building Regulations and the latest edition of BS EN 15287-1:2007, Design, Installation and Commissioning of Chimneys should be followed.

A flue draught of minimum 12 Pascals is required for satisfactory appliance performance. The flue draught should be checked under fire at high output and if it exceeds 25Pa, a draught stabiliser may be required so that the rate of burning can be controlled, and to prevent possible over-firing.

If you have any doubts about the suitability of your chimney, consult your local dealer/stockist. He will also be able to provide advice about the possible need for a specialist cowl.

The chimney must be swept before connection to the stove and swept every twelve months thereafter. It is recommended that your chimney is swept every six months.

An existing fireplace opening can be modified to accommodate the stove. The following pages identify some typical installation scenarios and provides the necessary specific installation information for your new stove. Always consult your stove supplier for a detailed survey of your particular circumstances. To make it easier to handle the stove on installation, remove the baffle plates, bricks and door. Place in a secure place to avoid damage. Refit after installation.

Upon completion of installation, the appliance should be checked under fire for soundness of joints and seals, and also that all smoke and fumes are taken from the appliance, up the chimney and emitted safely.

### **Typical Installation for Inglenook Fireplaces – top flue**

Inglenook fireplaces can have very large bore chimneys. Check with your installer – you are likely to require a stainless steel flexible liner for solid fuel if your chimney is larger than 230mm x 230mm. A closure plate with access for cleaning may also be required together with a short length of flue pipe of the same diameter as the stove flue collar.

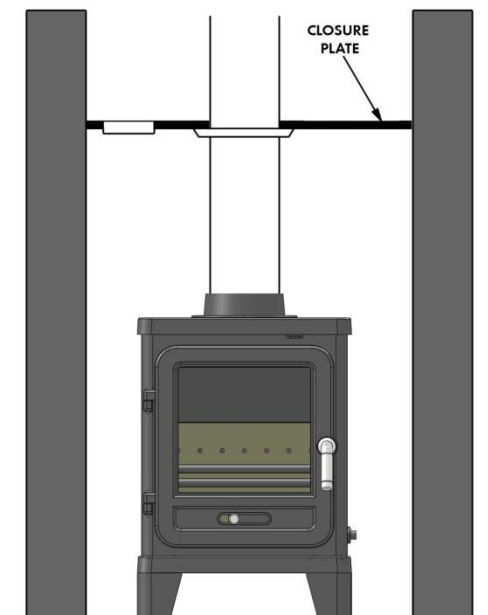

## Typical Installation for Inglenook Fireplaces – rear flue – Side View

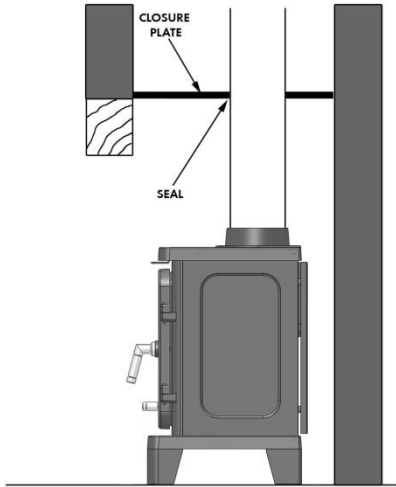

## Typical Installation Into In-filled Masonry Fireplaces

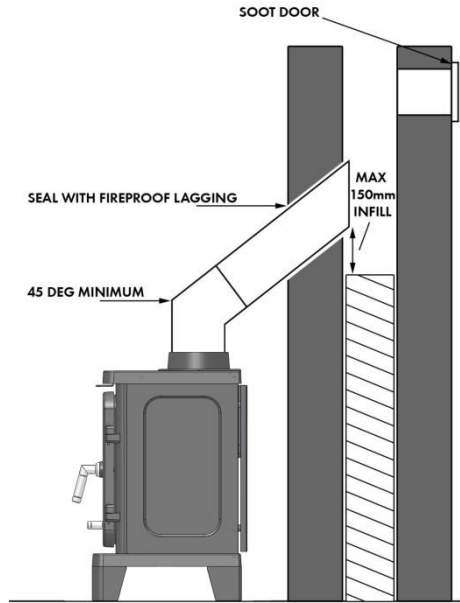

## SPECIFIC INSTALLATION INFORMATION

### Legs

Remove the legs from inside the stove. Carefully lay the stove on its back and using the screws provided fit the legs in place. Carefully set the stove upright and check that all internal components are correctly positioned.

### Clearances

If the stoves are to be installed adjacent to materials that can catch fire like wood then the following clearances must be adhered to:

STOVE	BACK (mm)	SIDES (mm)
Vega Edge 100	600	600
Vega Edge 200	600	600
Vega Edge 200SL	600	600



The stove can be recessed into a suitably sized fireplace built from non-combustible materials, but a permanent free air gap of at least 100mm should be left around the sides and top to obtain maximum heat output and for access to the rear of the stove.

It is possible to fit the stove with less clearance around it – down to 50mm, but the non-combustible material around it must be at least 150mm thick. This is normally achieved when installing into a standard brick-built chimney breast with double thickness walls to the rear and sides of the builder's opening. Take care that the wall finish is suitable to withstand temperatures of up to 200°C.

## **Hearths**

Allow an apron of at least 225mm at the front of the stove and 150mm on either side. Care should be taken to level the stove and secure the hearth. If existing floors do not have adequate load bearing capacity then suitable modifications must be adopted. All other standard thickness hearths are suitable too.

When the stove is in the desired position, fix the brackets provided to the back feet and level the stove using the levelling screws, then mark the hearth through the holes, remove the stove, and drill and plug the hearth for securing the stove.

**Ventilation Into a Room For Combustion Air is an Essential Requirement.  
Any apertures provided for this purpose must not be restricted or blocked.**

## **Flues Without a Flue Draft Stabiliser**

**Vega Edge 100 & Vega Edge 200SL** - When installing without a flue draft stabiliser into houses built before 2008, no additional permanent ventilation will be required. Houses built after this date will require additional means of permanent ventilation direct to outside of at least 2750 mm<sup>2</sup>. Penman Vents can be used for this.

**Vega Edge 200** - When installing without a flue draft stabiliser into houses built before 2008 at least 2200mm<sup>2</sup> additional means of permanent ventilation direct to outside is required. For houses built after 2008 at least 4950mm<sup>2</sup> additional means of permanent ventilation direct to outside is required. Penman Vents can be used for this.

## Flues With a Flue Draft Stabiliser

**Vega Edge 100 & Vega Edge 200SL** - When installing with a flue draft stabiliser into houses built before 2008, at least 1500mm<sup>2</sup> additional means of permanent ventilation direct to outside is required. Houses built after this date will require additional means of permanent ventilation direct to outside of at least 4250 mm<sup>2</sup>. Penman Vents can be used for this.

**Vega Edge 200** - When installing with a flue draft stabiliser into houses built before 2008 at least 4900mm<sup>2</sup> additional means of permanent ventilation direct to outside is required. For houses built after 2008 at least 7650mm<sup>2</sup> additional means of permanent ventilation direct to outside is required. Penman Vents can be used for this.

### Top or Rear Flue

Remove the collar and accessory pack from the stove. The stove will arrive with the blanking plate fitted to the rear. This can be removed if required allowing the collar to be fitted for rear flue installations. The circular cut out in the rear heat shield must be removed to enable this style of connection – see image below.

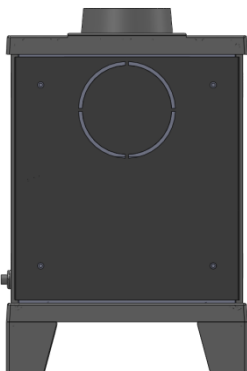

Remove the panel from the stove by unscrewing the four screws and then remove the circular cut out for rear flue installations. Replace the rear heat shield.

Remember to fit the blanking plate to the unused flue position if it has been removed.

## **OPERATION**

### **ALWAYS OPEN THE STOVE DOOR SLOWLY AND ALWAYS USE THE GLOVE**

#### **Primary Air**

Primary air is controlled via the sliding vent in the bottom of the door. This provides an air draught to the bed of the fire. Slide right to open and left to close. Open this when you start a fire, and to regulate anthracite fires. It should be closed when a wood fire is established for the best efficiency.

#### **Secondary Air**

Secondary air is controlled via the sliding vent above the door, it is this 'airwash' that keeps a clean and uninterrupted view of the fire, also aiding good secondary combustion of fuel and reducing emissions into the chimney and environment. Slide to the right to open and to the left to close. Use this to control wood fires. It should be closed when burning anthracite for the best efficiency after the fire is established.

#### **Tertiary Air**

A tertiary air supply is bled into the stove from the rear panel. Its function is to ignite unburned gasses assisting with a clean burn. It is advisable to clear these holes from time to time with a brush, especially when the stove is being serviced or after long periods of burning – particularly if "dirty" fuels such as damp wood or bituminous coal are used. **ONLY CARRY OUT THIS AND ALL SERVICING PROCEDURES WHEN THE STOVE IS COLD.** This tertiary air supply is permanently open and allows a small amount of air into the stove. Operation with air controls open can cause excess smoke. These stoves must not be operated with air controls left open except as directed in these instructions.

#### **Lighting the Stove**

It is essential that you have three or four small fires before you operate the stove to its maximum heat output. This is to allow the paint to cure and to "temper" your cast iron stove. We recommend this 'running-in' procedure after long shutdowns to preserve the life of stove. During the curing of the paint you may notice an unpleasant smell. It is not toxic, but for your comfort we would suggest that during this period you leave doors and windows open.

First, load the fire with starting fuel i.e. paper, dry kindling timber (about the thickness of your thumb) and/or firelighters in the mode chosen, either wood or coal products. **It is normal to see smoke come from the open stove door at this stage.**

Light the fire at base leaving all air controls open. Allow the fuel to reach a steady glow and build up the fire gradually. Once you have a good fire established across the fire bed, further fuel can be added as required.

When your fire is well established you can start to restrict the primary air intake. If you are burning only wood, the primary air control can be fully closed. If you are burning solid fuel you will require some primary air. Your stove is burning with maximum efficiency when a bright fire is achieved using minimum air inlet and the Penman Stove Thermometer (purchased separately) registers within the "Best Burn" range.

## **Wood Burning**

Wood burns best on a bed of ash and it is therefore only necessary to remove surplus ash from the grate occasionally. Burn only kiln dried or well-seasoned wood, which should have been cut, split and stacked under cover for at least 36 months, with free air movement around the sides of the stack to enable it to dry out. Burning wet or unseasoned wood will create tar deposits in the stove and chimney and will reduce heat output. Tar deposits, if allowed to build up, are a major cause of chimney fires. This tar also is the main cause of blackened stove windows. A Penman wood moisture meter is a handy device to have.

**Vega Edge 100** - Once established and for the best results from your stove, load about 1.5 to 2 kg of good quality dry wood per hour with the primary air control fully closed and the secondary air control about half to two-thirds closed. Logs can be up to 300mm or 12" long. Do not overload.

**Vega Edge 200** - Once established and for the best results from your stove, load about 2 to 3 kg of good quality dry wood per hour with the primary air control fully closed and the secondary air control about half to two-thirds closed. Logs can be up to 300mm or 12" long. Do not overload.

**Vega Edge 200SL** - Once established and for the best results from your stove, load about 1.5 to 2 kg of good quality dry wood per hour with the

primary air control fully closed and the secondary air control about half to two-thirds closed. Logs can be up to 300mm or 12" long. Do not overload.

Of course, best burning depends on the quality of wood, draft and stove settings, so please do experiment to find your own best settings and the best position on your Stove Thermometer.

### **Other Solid Fuel Burning**

Always clean out the ash pan before refuelling and do not let the ash build up to the underside of the grate bars – this will severely reduce the life of the grate and prevent efficient burning. Solid fuel produces ash, which if allowed to build up, will stifle the air flow through the grate and eventually cause the fire to die.

**Caution** – only empty the ash pan when the stove is cool.

With some solid fuels a residue of burnt fuel or clinker will accumulate on the grate, allow the fire to go out periodically to remove this.

**Vega Edge 100** - Once established and for the best results, load about .75 kg of anthracite or equivalent per hour with the primary air control about half to three quarters open and the secondary air control fully closed. Do not overload.

**Vega Edge 200** - Once established and for the best results, load about 1.5 to 2 kg of anthracite or equivalent per hour with the primary air control about half to three quarters open and the secondary air control fully closed. Do not overload.

**Vega Edge 200SL** - Once established and for the best results, load about .75 kg of anthracite or equivalent per hour with the primary air control about half way open and the secondary air control fully closed. Do not overload.

When loading fuel, ensure that the series of tertiary air holes on the rear chamber brick are not covered by the fuel.

Of course best burning depends on the type of fuel being burnt, draft and stove settings, so please do experiment to find your own best settings.

### **De-Ashing**

During stove use, whilst burning anthracite or a mix of wood and anthracite, from time to time the riddler must be used to remove ash ensuring airflow

through the fire bed and allowing the fire to burn over the whole grate. The riddling knob is located on the right hand side of the stove. The supplied stove tool must be used to turn this knob. Placing the 'spanner' end of the tool over the knob, rotate the tool clockwise and anti-clockwise – back and forwards until the fire shows signs of more air reaching un-burnt fuel. Do not force this mechanism if it becomes very hard to move – there may be some debris caught in the grate – if this is the case, carefully open the stove and using a poker in a gloved hand, gently agitate the fuel bed.

## **Recommended Fuels**

*Please note that HETAS Ltd Appliance Approval only covers the use of wood logs and approved smokeless fuels on this appliance. HETAS Ltd. Approval does not cover the use of other fuels either alone or mixed with the recommended fuels listed above, nor does it cover instructions for the use of other fuels*

**Wood** - Only kiln-dried or well-seasoned wood with a moisture content reading of less than 18% is recommended. A Penman moisture meter is a handy device to have and is available from your supplier. As a rule-of-thumb, wood seasons at about 1" (25mm) per year, so a log split such that along its length no dimension is greater than 3" (75mm), it would take about 3 years to dry. A dry log will produce up to four and a half times more heat output than a freshly cut log. Wet logs take heat to dry.

**Other Solid Fuel** – "Authorised" fuels include anthracite large nuts, briquettes smokeless fuel, ie. Ancit, Phurnacite, Taybrite, Homefire Ovals suitable for closed appliances. Bituminous coals can cause tar deposits and burn very hot, so mix with other fuels and use sparingly.

## **Unauthorised Fuels**

DO NOT burn Wildfire, Housecoal, household coal, petroleum cokes or household waste. If in doubt consult your merchant or the Solid Fuel Association.

Please note that when refuelling with solid fuel, do not pile fuel higher than 30 degrees from the front bar rearwards – over-fuelling can cause excess smoke and produce temperatures beyond the designed rating of the appliance causing damage to internal parts.

The Vega Edge 100, Vega Edge 200 & Vega Edge 200SL are designed to be operated with the door closed, except for refuelling. Not only is it unsafe to operate with the door open but the appliance efficiency will be significantly reduced and excess smoke can occur.

The Vega Edge 100, Vega Edge 200 & Vega Edge 200SL are designed to operate intermittently and must not be used as an overnight burner.

### **Clean Burn - The Clean Air Act 1993 and Smoke Control Areas**

Local authorities may declare the whole or part of their zone to be a smoke control area. It is an offence to emit smoke from a chimney of a building if located in a designated smoke control area. It is also an offence to acquire an "unauthorised fuel" for use within a smoke control area unless it is used in an "exempt" appliance.

The Secretary of State for Environment, Food and Rural Affairs has powers to authorise smokeless fuels or exempt appliances for use in smoke control areas in England. In Scotland and Wales this power rests with Ministers in the devolved administrations for those countries. Separate legislation, the Clean Air (Northern Ireland) Order 1981, applies in Northern Ireland. Therefore it is a requirement that fuels burnt or obtained for use in smoke control areas have been "authorised" and that appliances used to burn solid fuel in those areas (other than "authorised" fuels) have been exempted for each area of administration. Further information on the requirements of the Clean Air Act can be found here: <https://www.gov.uk/smoke-control-area-rules>

The Vega Edge 100, Vega Edge 200 & Vega Edge 200SL have been recommended as suitable for use in smoke control areas when burning dry wood and the "authorised" smoke free solid fuels.

The "authorised" solid fuels you are permitted to burn in a smoke control zone include: anthracite (this is naturally occurring smokeless fuel and is the test fuel normally used and recommended), Ecoal 50, Homefire, Homefire ovals, Phurnacite, Taybrite and Multiheat.

### **Refuelling Onto a Low Fire Bed**

If the fire bed is not sufficient to light a new fuel charge, excessive smoke emission can occur. Refuelling must be carried out onto a bed of glowing embers and ash such that the new fuel ignites in a reasonable period. If there are too few embers in the fire bed, add kindling to prevent excessive smoke.

### **Fuel overloading**

The maximum amount of fuel specified in this manual should not be exceeded, overloading can cause excess smoke.

### **Operation with door left open**

Operation with the door open can cause excess smoke. The appliance must not be operated with the appliance door left open except as directed in the instructions.

### **Dampers left open**

Operation with the air controls or appliance dampers open can cause excess smoke. The appliance must not be operated with air controls, appliance dampers or door left open except as directed in the instructions.

### **GENERAL MAINTENANCE (only ever carry out maintenance when the stove is cold).**

The following elements of maintenance may be carried out by the householder. Any structural repairs, e.g. panel, collar or stove pipe replacement must be carried out by a suitably qualified installer.

### **Baffle Plate Removal and Replacement**

Note the position before removal. To remove baffle plate, firmly push the baffle plate upwards then bring forwards so that the back edge of the baffle plate drops down from the rear fire brick that it was resting upon. The plate can now be withdrawn through the open doorway of the stove.

To replace, place the baffle plate inside the stove in the correct alignment. Angle the plate so that the front edge is higher than the back edge and lift high into the stove so that the front edge locates on the steel ledge at the top of the stove and the back edge of the plate can be re-positioned on top of the rear fire brick.

### **Sweeping the Chimney**

Your chimney should be cleaned each year before starting to use your stove for the winter. Birds may have nested in the chimney or the masonry may have cracked. Both chimney and flue pipe must be swept at least once a year. It is recommended that you have your chimney swept every six months. It may be necessary to sweep more frequently when damp wood is burnt regularly. The chimney can be swept through your stove with the baffle plate removed. It is advisable to remove the bricks too in order to avoid accidental damage.



### **Inner Grate Removal and Replacement**

Remove the ash pan and detach the riddling arm from the underside of the circular inner grate. Lift the inner grate vertically and manoeuvre it out of the stove. When replacing, ensure the riddling arm is re-connected to the inner grate.

### **Outer Grate Removal and Replacement**

Remove all the bricks and the inner grate. Lift the outer grate up at an angle left higher than right and manoeuvre the grate out left side first.

### **Stove Body**

The stove is finished with a heat-resistant paint and this can be cleaned with a soft brush. Do not clean whilst the stove is hot – wait until it has cooled down. The finish can be renovated with Penman Stove Paint available from your supplier.

### **Glass Panels**

Clean the glass panels when cool with Penman Glass Cleaner. Highly abrasive substances should be avoided as these can scratch the glass and make subsequent cleaning more difficult. Wet logs on heated glass, a badly aimed poker or heavy slamming of doors could crack the glass panels. The glass will not fracture from heat.

Should a glass panel require replacement, then remove the four screws and clips retaining the glass frame, carefully remove the broken glass and replace the panel with the correct stove glass from your supplier. Ensure you use new glass fibre seal around its edge, and use the steel frame, clips and screws to retain it in position.

### **Seasonal Maintenance**

If your stove is to be unused for any length of time, e.g. summer months, then it is recommended that it is cleaned out thoroughly. Air slides should be lightly oiled with WD40 or similar and left partially open to allow air circulation. Regular monitoring of the inside components will identify condensation or water ingress. If these problems occur, then your stove needs to be dried and the cause of the problem rectified. After a shut-down, and before reuse, the appliance should be cleaned again and the chimney swept, it is essential to have the chimney swept at least once annually and it is recommended that it is swept twice a year.

## **Safety Notes and Troubleshooting**

**IT IS ESSENTIAL AND REQUIRED BY BUILDING REGULATIONS THAT A CO ALARM IS INSTALLED IN THE SAME ROOM AS THIS APPLIANCE.**

### **Fires Can Be Dangerous**

Always use a fire guard to BS 8423:2002, Fireguards for Use With Solid Fuel Appliances, in the presence of children, the elderly or the infirm. Inform all persons of the dangers of high temperatures during operation of appliance including the stove pipe.

Do not use this stove as an overnight burner, when finished for the evening, leave the air controls open to allow the remainder of the fuel to burn out.

Use the glove provided to open the door and never empty the ash pan when it is hot.

### **Do Not Over-Fire**

It is possible to fire the stove beyond its design capacity, this could damage the stove, so watch for signs of over-firing – if any part of the stove starts to glow red, the fire is in an over fire situation, and the controls should be adjusted accordingly. Never leave the stove unattended for long periods without adjusting the controls to a safe setting – careful air supply control should be exercised at all times and only add the recommended quantity of fuels.

### **Smoke and Fumes Entering the Room**

When properly installed and operated, this appliance will not emit fumes into the room. Occasional fumes from de-ashing and refuelling may occur and is normal. Persistent fume emission with closed doors must not be tolerated.

If fume emission does persist, then the following immediate action should be taken:

1. Evacuate the room, opening doors and windows on your exit to ventilate the room.
2. Let the fire go out, or eject and safely dispose of fuel from the appliance.

3. Check for a flue blockage and clean if required.

Do not attempt to relight the fire until the cause has been identified and corrected. If necessary, seek professional advice.

These situations are very dangerous and must NOT be tolerated. A list of Qualified Engineers is available from

UK Solid Fuel Association  
7 Swanwick Court  
Alfreton  
Derbyshire  
DE55 7AS  
Tel. 0845 601 4406

R. o. I.  
Irish National Fireplace Organisation  
162 Chapel Street  
Dublin  
Ireland  
Tel. 01 801 5959

### **Chimney Fire**

Identified by loud roaring sounds, dense smoke and sparks exiting chimney. Shut down all air supply to stove by closing air vents, ensure the stove door fully closed, call the Fire Brigade immediately. Regular chimney maintenance will prevent chimney fires. Seek advice from a qualified chimney sweep. Chimneys must be checked at least annually or more often when poor quality fuels that are not recommended are burnt

### **Poor Heat Output**

#### **Stove too small for room**

Seek advice from a qualified heating engineer as to (kW) output required for room size. As a guideline the volume of the room in cubic feet divided by 500 i.e. room 15' x 15' x 8' would require 3.6kW approx.

#### **Chimney and / or flue pipe restricted, room ventilation restricted.**

On Installation these will have been checked but regular maintenance is necessary as conditions can change i.e. soot build up, birds nesting, masonry fall, dust build up or furniture blocking vents.

#### **Poor quality fuel.**

Only burn dry seasoned timber, soft woods have a lower heat output than hard woods. Use the Penman Moisture Meter. Solid fuels vary in heat value, check with your coal merchant as to suitability.

## **Dirty Glass**

Nearly always caused by poor fuel quality – check the moisture content of the wood you are burning with a Penman moisture meter.

Fire burning too low, open the air vents on the stove to create a hot fire, this may 'burn' the glass clean.

If glass requires cleaning use Penman glass cleaner from your supplier, only use glass cleaner on cold glass. **DO NOT USE** abrasives or scrapers, these will scratch the glass making tar build up harder to remove. **NEVER** spray aerosols near the appliance when it is alight.

## **Un-burnt Fuel**

Insufficient air reaching fuel - Adjust the air controls to supply combustion air to burn fuel fully. Check if the ash pan is full, empty if required. Front bar/fret may be blocked, de-ash. Check for jammed clinker or nails in grate when the fire is out and cold.

## **STOVE ACCESSORIES**

The following is a list of stove accessories your retailer will be able to supply:

- Penman matching graphite high temperature paint
- Stove Glass Cleaner
- Spare Rope
- Rope Seal Adhesive
- CO Detector
- Penman Stove Fan
- Penman Stove Thermometer
- Wood Moisture Meter
- Spare Glove
- Permanent Ventilators
- Purpose-built Ash Vacuum Cleaner
- Penman Ash Carrier
- Penman Fire Screens
- Penman Companion Sets
- Penman Log Baskets
- Penman Soot Box



Brought to you by Percy Doughty & Co  
Imperial Point, Express Trading Estate, Stone Hill Road,  
Farnworth, Bolton. BL4 9TN  
01204 868 550  
[www.penmancollection.co.uk](http://www.penmancollection.co.uk)